

PD SERIES



NOTICE

- This product is not intended for life or safety applications.
- Do not install this product in hazardous or classified locations.
- Read and understand the instructions before installing this product.
- Turn off all power supplying equipment before working on it.
- The installer is responsible for conformance to all applicable codes.

PRODUCT IDENTIFICATION

Range	Material	Output
PD	A	M
50 = 0 to 50 psig 100 = 0 to 100 psig 250 = 0 to 250 psig 500 = 0 to 500 psig 1000 = 0 to 1000 psig	= 17 - 4 SS	= 4-20 mA

DIMENSIONS

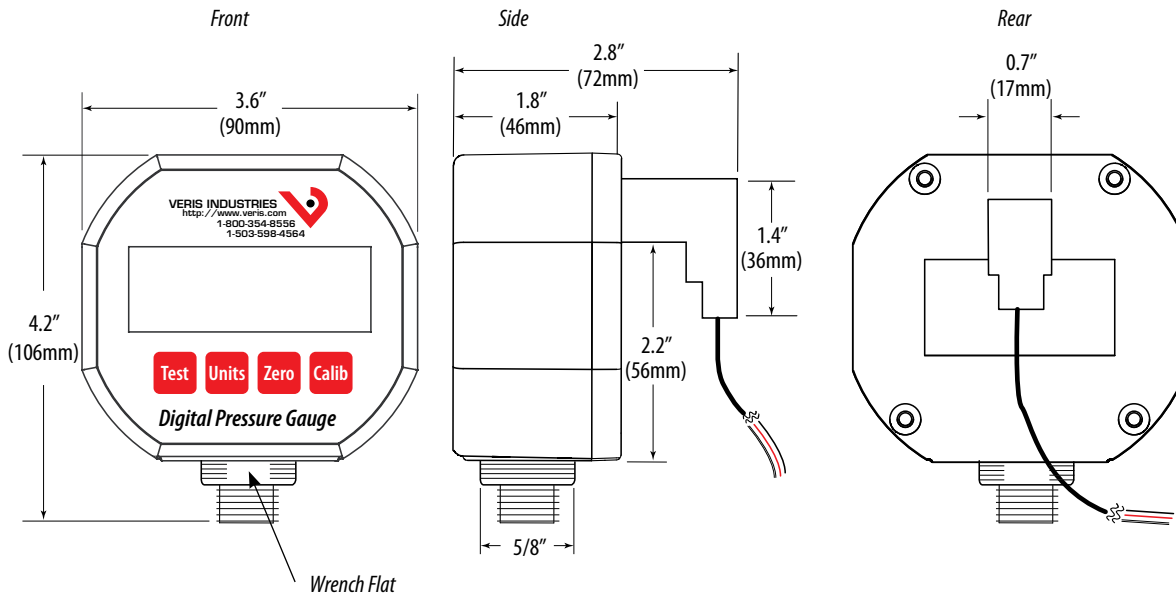

(Tighten with a 5/8" wrench at this spot. Do not tighten by twisting the plastic PD housing.)

PD SERIES

Digital Pressure/Vacuum Gauge with Display and Analog 4-20 mA Output

Installer's Specifications

Measurement Units	Selectable: psi, bar, kg/cm ² , ATM, in. Hg, in. H ₂ O*
Accuracy**	< ±0.5% of F.S., BFLS
Overrange Protection	2x rated pressure
Burst Pressure	5x rated pressure or 5000 psi, whichever is less
Temperature Ranges:	
Operating (Ambient)	-10° to 70°C (15° to 158°F)
Storage	-40° to 65°C (-40° to 150°F)
Thermal Limits:	
Compensated Range	0° to 55°C (32° to 131°F)
TC Zero	< ±1.5% of F.S.
TC Span	< ±1.5% of F.S.
Connection	¼" NPT, male
Power***	7.5 to 32 VDC
Housing	Polycarbonate
Environmental Protection	NEMA 4, IP65
Output	4-20 mA loop powered

* in. H₂O units available on ≤250 psi range devices only

** Accuracy includes non-linearity, hysteresis and non-repeatability measured at 25°C/77°F

*** Select a loop power supply and total loop resistance such that when the loop current is 20 mA, the gauge will have at least 7.5 VDC at its terminals.

QUICK INSTALL

1. Select a location for the installation suitable to the gauge's physical dimensions that will allow access to the display and keypad. Plan for a ¼" M-NPT connection or a hose to a ¼" fitting.
2. Thread the gauge onto the fitting. Apply tightening torque only to the metal wrench flats, not to the PD housing. Use a 5/8" wrench. Do not overtighten.
3. Wire the device. See the wiring diagram in this guide.
4. Remove the protective film from the gauge front.
5. Program the gauge.

DESCRIPTION

PD analog digital pressure gauges are media isolated, so they can be used with any gas, liquid, or solid compatible with 17-4 PH stainless steel within the specified pressure range. The transducer consists of a one-piece, high-strength pressure sensor that uses no silicone oils, welds, O-rings, or seals. The sensor is coupled to a 4-20 mA loop powered internal display and keypad. The keypad controls setup and operation of the sensor as described below.

INSTALLATION AND WIRING

Allow space to turn the PD Analog onto the pipe or fitting during mounting. The PD is delivered with the connector attached to the device.

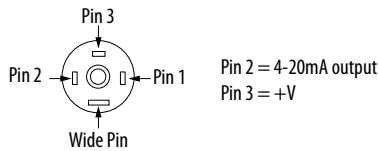
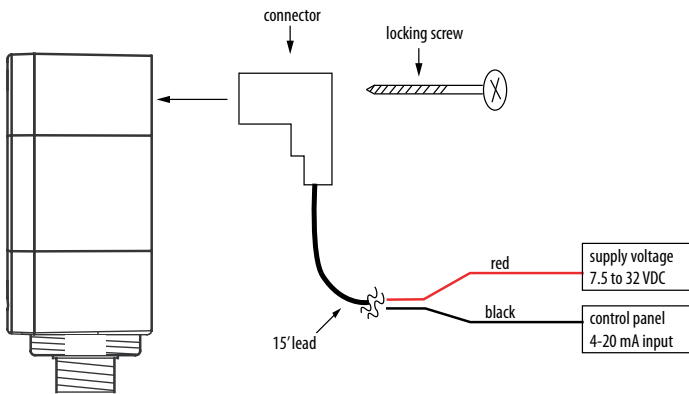
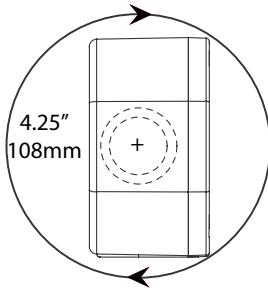

Electrical

Select a loop power supply voltage and total loop resistance such that when the loop current is 20 mA, the gauge will have at least 7.5 VDC at its terminals. Too large a loop resistance will cause the gauge output to "limit" or saturate before reaching its full 20 mA output.

The minimum loop supply voltage is calculated from the formula:

$$V_{min} = 7.5V + (20mA * \text{total loop resistance}).$$

If the loop voltage drops too low, the PDxAM will display the LOW LOOP icon. At this time, all calibration functions are disabled.

The LCD is loop-powered. If no voltage is applied, or if the connector is removed, the display will be blank.

NORMAL OPERATION

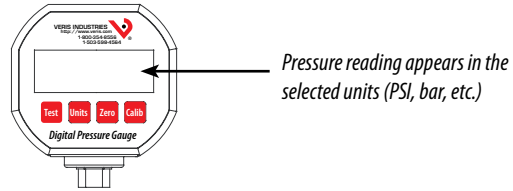

To select/change display units:

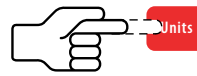

Note: The UNITS button does not affect the mA output.

Output signal:

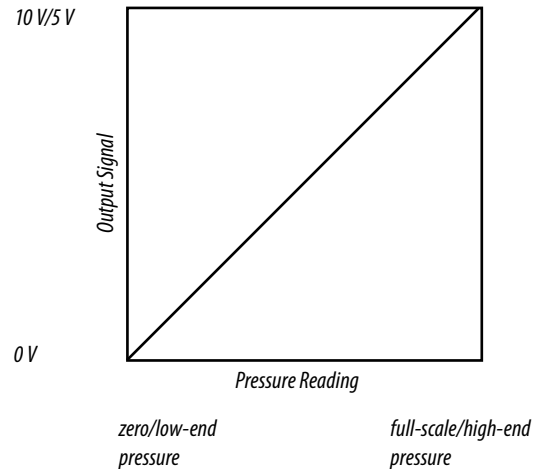

Note: For out-of-scale pressure readings, output can go as low as 3.5mA or as high as 24mA.

TEST

To switch the PD into Test Mode, press and hold down the TEST button. The Test Mode allows setup and testing of the output voltage without altering the system pressure. To change the test output level, press and hold the TEST button, and press the CALIB button while holding TEST. Each time the CALIB button is pressed, the test level output increases by 2 mA.

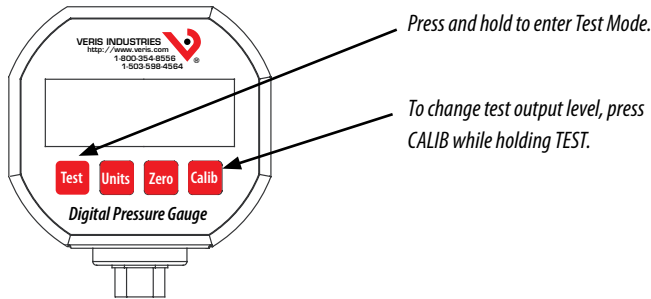

ZERO PRESSURE CALIBRATION

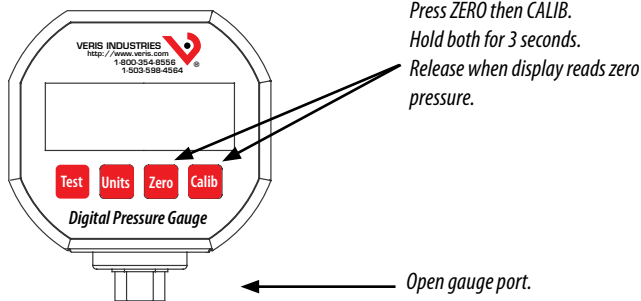

The PD can be re-zeroed without affecting the span calibration. The gauge port must be open with no pressure or vacuum applied.

Perform this step when pressure units show in the display (not mA). Zero calibration is retained after unit is turned off.

SPAN PRESSURE CALIBRATION



1. Press to select pressure units.



2. Press and hold for 3 seconds, until display alternately reads "CAL" and the calibration pressure (e.g. "CAL" and "500" to calibrate at 500 psi).

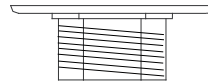

3. Connect the gauge port to a pressure reference of known accuracy. Apply pressure level selected in Step 2.



4. Press and hold the CALIB button for 3 seconds until display reads "DONE." Calibration is now complete.

Notes:

Only attempt Span calibration if the user has access to a pressure reference of known accuracy. Use calibration equipment with at least four times the gauge accuracy. Perform Zero calibration before span calibration.

If the user tries to calibrate the unit beyond $\pm 10\%$ of the factory calibration, the display will read "ERR" indicating an erroneous calibration.

To cancel calibration, press and release the CALIB button.

To restore factory calibration, repeat steps 1 and 2, then hold the ZERO button for 3 seconds, until the display reads "FAC."

CURRENT OUTPUT CALIBRATION

The current output on the PD analog pressure gauge has been set at the factory. These setting will not normally need adjustment. Perform these steps only if necessary.



1. Press to select the mA units.

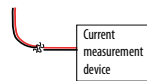

2. Connect the leads to an accurate current measurement device.



3. Press and hold for 3 seconds, until the display flashes between "CAL" and "4.00." Set the loop current to 4.00 mA



4. Press TEST to decrease the output by 0.01 mA. Press UNITS to increase the output. While the output will change, the display will not.



5. Press and hold for 3 seconds to accept the calibration at 4.00 mA. The display will change to "CAL" and "20.00."

6. Repeat steps 3 through 5 to calibrate at 20 mA. Display will now read "DONE."

Notes:

To cancel calibration changes, briefly press and release the CALIB button.

To restore factory calibration, repeat step 3 only, then hold the ZERO button for 3 seconds, until the display reads "FAC."